

ORBITAL MAINTENANCE FOR THE WIDE FIELD INFRARED SURVEY TELESCOPE: THE EFFECTS OF SOLAR RADIATION PRESSURE AND NAVIGATION ACCURACIES ON STATIONKEEPING

Ariadna Farres¹, Cassandra Webster², Jennifer Donaldson³, Dave Folta⁴

The Wide-Field Infrared Survey Telescope (WFIRST), a NASA observatory designed to investigate dark energy and astrophysics, is planned for a launch in 2025 to orbit the Sun-Earth L2 (SEL2) Libration Point. Due to the instability of the SEL2 environment, WFIRST must perform maneuvers to remain in its mission orbit. This paper investigates how different error sources affect the resulting stationkeeping Δv for WFIRST. We study how Solar Radiation Pressure (SRP) modeling affects WFIRST's orbital motion and stability, and how SRP combined with Orbit Determination (OD) errors drive the stationkeeping maneuver magnitudes. Our goal is to determine the best way to model WFIRST's SRP so that we minimize its impact on total stationkeeping Δv required over the mission lifetime.

INTRODUCTION

The Wide-Field Instrument Survey Telescope (WFIRST) is a NASA observatory designed to answer questions about dark energy, exoplanets and astrophysics. WFIRST will utilize a 2.4 meter primary mirror (the same size as the Hubble Space Telescope's) along with a Wide-Field Instrument (WFI) and Coronagraph Instrument (CGI) to achieve its mission objectives. The WFI will have a field of view 100 times greater than the Hubble Space Telescope, allowing WFIRST to capture more area of the sky in less time. With its large field of view, the WFI will be able to measure the light from a billion galaxies throughout WFIRST's mission lifetime, and will also perform a survey of the inner Milky Way using microlensing to find close to 2,600 exoplanets. While the CGI will be used to perform high contrast imaging and spectroscopy of closer exoplanets.

WFIRST is planned for launch in 2025 to orbit in a Quasi-Halo orbit at the Sun-Earth L2 (SEL2) Libration Point. Due to the instability of the SEL2 environment, WFIRST is required to perform routine stationkeeping maneuvers. WFIRST will also need to perform routine Momentum Unloads (MUs) to unload stored momentum in the reaction wheels. In order to plan these stationkeeping

¹ Visiting Researcher, University of Maryland Baltimore County, Baltimore, Maryland.

² WFIRST Flight Dynamics Lead, NASA Goddard Space Flight Center, Greenbelt, Maryland.

³ WFIRST Deputy Flight Dynamics Lead, NASA Goddard Space Flight Center, Greenbelt, Maryland.

⁴ Senior Fellow, NASA Goddard Space Flight Center, Greenbelt, Maryland.

maneuvers, WFIRST is considering both ground-based and on-board based navigation methods to help plan these maneuvers accurately.

The baseline trajectory for WFIRST has been computed using the Adaptive Trajectory Design (ATD) module [1], where the Earth-Sun Restricted Three Body Problem (RTBP) is used as a simplified model to find a transfer trajectory to a Quasi-Halo orbit using Dynamical System Theory (DST), hence using the invariant manifolds to find a natural transfer trajectory. A second higher fidelity force model including the gravitational attraction of the Sun, Earth, Moon and Solar Radiation Pressure (SRP) is then used to refine this transfer trajectory and find a 10-year Quasi-Halo reference orbit for WFIRST. In this paper, we will focus on how the orbital maintenance of WFIRST at SEL2 is affected by Solar Radiation Pressure (SRP) and Orbit Determination (OD) errors.

The stationkeeping strategy used to remain close to the reference Quasi-Halo orbit uses information from the dynamics of the system. Each time a stationkeeping maneuver is required, we compute the State Transition Matrix (STM) of the satellite's trajectory over one period, and compute the stable and unstable eigenvectors of this matrix. Then a Δv maneuver, applied in the stable direction, is performed which minimizes the insertion to the reference orbit. In order to plan these stationkeeping maneuvers, the Flight Dynamics team needs to know WFIRST's position and velocity within certain accuracies (typically within a certain percentage of the notional stationkeeping Δv magnitude). Using ground-based navigation techniques, such as receiving tracking data from the NASA Near Earth Network (NEN) and Deep Space Network (DSN) ground stations, the Flight Dynamics team can determine and predict WFIRST's position and velocity to single digit km and double digit mm/sec accuracies. This is a standard practice, usually called Orbit Determination, which satellites have used for years. Another technique for OD is to use an on-board navigation system with star trackers/cameras, accelerometers, and stable oscillators. With an on-board system, a satellite can determine its own position and velocity by taking angular measurements between known dynamic celestial bodies (Earth and Moon, Earth and a known star, Earth and other planets, etc.) and receiving one-way Doppler from the ground stations. The position and velocity accuracy of the on-board solution depends on multiple factors including how frequent an angle measurement can be taken, the accuracy of the on-board oscillator and the star camera, the celestial objects in the field of view of the camera, and the accuracy of the filter dynamics model. In general, though, an on-board system is as accurate (in some cases more-so) than a ground-based system. In this paper, we will see how the ground-based navigation accuracy affects the total amount of fuel required for stationkeeping on WFIRST, but in the future, WFIRST plans to investigate the possibility of an on-board system, as well.

While having an accurate navigation solution is necessary for the stationkeeping planning, an accurate model of the SRP is also desired in order to help minimize the total Δv required for each stationkeeping maneuver. Hence in this paper we study the effect of the SRP on the orbital dynamics and the stationkeeping maneuvers, based on a reference attitude profile for WFIRST, while considering different SRP models (the cannon-ball model, the N-plate model and a Finite Element approximation). The goal is to understand how SRP can influence the orbital maintenance and also what level of fidelity is required for the mission.

In this paper, the first section describes the force models that are considered and a brief description on the different SRP models. The second section is devoted to the SRP analysis, where we discuss the direct and indirect effects of SRP on the natural dynamics of Halo orbits and stationkeeping. Section three shows the impact of the navigation accuracy on the maneuver planning. Finally, some conclusions and future work are discussed.

FORCE MODELS

The main forces that affect the trajectory of WFIRST are the gravitational pull of Earth, Moon, and Sun. To design the mission baseline for WFIRST we have used different force models, the Circular Restricted Three Body Problem (RTBP) and a higher fidelity one including the gravitational pull of Earth, Moon, and Sun. In both models the main bodies are considered to be point masses. A relevant perturbation to WFIRST motion around its nominal orbits is SRP which can be modeled up to different fidelity levels. For the sake of completeness let us briefly describe here the different force models that have been used in this study.

Circular Restricted Three Body Problem

We recall that the Sun-Earth circular Restricted Three Body Problem considers the satellite to be a massless particle that is affected by the gravitational attraction from Sun and Earth, each assumed to be point masses evolving around their mutual center of mass in a circular motion. We also include the effect due to SRP. We consider a rotating reference frame, where the origin is at the Sun-Earth center of mass and the two primaries are fixed on the x-axis (with the positive side pointing towards the Earth); the z-axis is perpendicular to the ecliptic plane and the y-axis completes an orthogonal positive oriented reference frame. Normalizing the units of mass, distance, and time such that the total mass of the system is 1, the Sun-Earth distance is 1 and the period of one Sun-Earth revolution is 2π , the equations of motion are:

$$\begin{aligned}\ddot{X} - 2\dot{Y} &= 2X - \frac{1-\mu}{r_{ps}}(X+\mu) - \frac{\mu}{r_{pe}}(X+1-\mu) + a_x, \\ \ddot{Y} + 2\dot{X} &= 2Y - \left(\frac{1-\mu}{r_{ps}} + \frac{\mu}{r_{pe}}\right)Y + a_y, \\ \ddot{Z} &= -\left(\frac{1-\mu}{r_{ps}} + \frac{\mu}{r_{pe}}\right)Z + a_z,\end{aligned}\tag{1}$$

where $r_{ps} = \sqrt{(X+\mu)^2 + Y^2 + Z^2}$, $r_{pe} = \sqrt{(X-1+\mu)^2 + Y^2 + Z^2}$ are the Sun-satellite and Earth-satellite distances, and $\mathbf{a}_{srp} = (a_x, a_y, a_z)$ represents the SRP acceleration. Despite the simplicity of this model it is able to capture the most interesting dynamical properties of the satellite's motion in the Sun-Earth vicinity, and is used in many cases for preliminary mission analysis.

Point Mass Ephemeris Model

This is a higher fidelity model, which also considers the satellite as a massless particle that is affected by the gravitational attraction of Sun, Earth, and Moon, which are considered to be point masses that follow their true motion given by JPL DE421 ephemeris. We also include the SRP acceleration. Calling $\mathbf{R} = (X, Y, Z)$ the satellite's position and $\mathbf{R}_i = (X_i, Y_i, Z_i)$ the position of Sun, Earth, and Moon ($i = S, E, M$ respectively) and m_S , m_E , and m_M are their respective masses. The equations of motion are given by:

$$\ddot{\mathbf{R}}_{S,sc} = -Gm_S \frac{\mathbf{R}_{S,sc}}{R_{S,sc}^3} + Gm_E \left(\frac{\mathbf{R}_{E,sc}}{R_{E,sc}^3} - \frac{\mathbf{R}_E}{R_E^3} \right) + Gm_M \left(\frac{\mathbf{R}_{M,sc}}{R_{M,sc}^3} - \frac{\mathbf{R}_M}{R_M^3} \right) + \mathbf{a}_{srp},\tag{2}$$

where $\mathbf{R}_{S,sc} = \mathbf{R}_S - \mathbf{R}$, $\mathbf{R}_{E,sc} = \mathbf{R}_E - \mathbf{R}$, $\mathbf{R}_{M,sc} = \mathbf{R}_M - \mathbf{R}$, are the Sun – satellite, Earth – satellite, and Moon – satellite directions, respectively, and \mathbf{a}_{srp} represents the SRP acceleration. The position and velocities for the Sun, Earth and Moon are obtained through the evaluation of SPICE Toolkit⁵. Note that the rest of the planets can easily be included if desired.

Solar Radiation Pressure

Solar Radiation Pressure (SRP) is the acceleration caused by the exchange in momenta between the solar photons and the satellite's surface. The incident photons will be absorbed and reflected by the surface of the satellite, where the rate of absorption (ρ_a) and reflection (ρ_s, ρ_d), depend on the properties of the surface material. Hence, the total acceleration due to SRP will vary depending on the shape of the satellite, the reflectivity properties of the materials, and its relative orientation with respect to the Sun-satellite line. Despite being small compared to the gravitational attraction of the main bodies in the system, SRP plays an important role in the dynamics of Libration Point Orbits (LPO) [2] and its effect must be taken into account.

What is still under consideration is what level of fidelity this effect must be modeled during a preliminary mission analysis. Since the SRP modeling affects the overall ability to minimize the total Δv cost during the station keeping around a LPO, it is important to choose a SRP model with enough fidelity to produce valid results. Let us discuss the different existing models for the SRP acceleration.

Cannonball model. This is the simplest and most common approach used in the literature, where the satellite's shape is approximated by a sphere [3, 4]. In this case the SRP acceleration, \mathbf{a}_{srp} , is always in the satellite-Sun direction \mathbf{r}_s , and can be expressed as:

$$\mathbf{a}_{srp} = -\frac{C_r P_{srp} A_{sat}}{m_{sat}} \mathbf{r}_s, \quad (3)$$

where $P_{srp} = P_0 (R_0/R_{sun})^2$ is the SRP at a distance R_{sun} from the Sun ($P_0 = 4.57 \times 10^{-6}$ N and $R_0 = 1$ AU), (A_{sat}/m_{sat}) is the satellite's area-to-mass ratio, \mathbf{r}_s is the normalized satellite-Sun direction and $C_r \in [1, 2]$ is the reflectivity coefficient. The C_r is hard to predict and depends on the satellite's reflectivity properties. For instance, $C_r = 1$ means that all the sun-light is absorbed, while $C_r = 2$ indicates that it is all reflected and twice the force is transmitted to the satellite [4]. Note that in the RTBP reference frame (Eq. (1)) $\mathbf{r}_s = (X + \mu, Y, Z)/r_{ps}$, and in the high fidelity model (Eq. (2)) $\mathbf{r}_s = (X - X_S, Y - Y_S, Z - Z_S)/\mathbf{R}_{S,sc}$.

Given that P_{srp} depends on the inverse distance to the Sun similar to the Sun's gravitational attraction, it is common to rewrite Eq. (3) as:

$$\mathbf{a}_{srp} = -q_{srp} \frac{Gm_S}{r_{ps}^2} \mathbf{r}_s, \quad (4)$$

where $q_{srp} = C_r \cdot \left(\frac{A_{sat}}{m_{sat}}\right) \cdot \left(\frac{P_0 R_0^2}{Gm_S}\right) = C_r \cdot \left(\frac{A_{sat}}{m_{sat}}\right) \cdot 7.7065 \times 10^{-4}$, when A_{sat} is given in m² and m_{sat} is given in kg.

N-plate model. This model is an intermediate model, where the shape of the satellite is approximated by a collection of flat plates, each of them having different reflectivity properties, which

⁵ SPICE Toolkit <https://naif.jpl.nasa.gov/naif/toolkit.html>

represent the different parts of the satellite [4]. Here the magnitude of the SRP acceleration varies depending on the satellite's orientation with respect to the Sun-satellite line.

For a flat surface, the total force due to SRP is the sum of the forces produced by the absorbed photons ($\mathbf{F}_a = P_{srp}A\langle\mathbf{n}, \mathbf{r}_s\rangle\mathbf{r}_s$) and the reflected photons, which experience specular reflection ($\mathbf{F}_s = 2P_{srp}A\langle\mathbf{n}, \mathbf{r}_s\rangle^2\mathbf{n}$) and diffusive reflection ($\mathbf{F}_d = P_{srp}A\langle\mathbf{n}, \mathbf{r}_s\rangle(\mathbf{r}_s + \frac{2}{3}\mathbf{n})$). The coefficients ρ_a , ρ_s and ρ_d represent the rates of absorption, specular reflection and diffusion reflection, which depend on the plates' material properties, and satisfy $\rho_a + \rho_s + \rho_d = 1$ (hence $\rho_a = 1 - \rho_s - \rho_d$).

We can then define our satellite as a collection of N plates, where from each plate we know its area A_k , its reflectivity properties ρ_s^k, ρ_d^k and its alignment with respect to the Sun given by the normal vector \mathbf{n}_k , the total SRP acceleration given by:

$$\mathbf{a}_{srp} = -\frac{P_{srp}}{m_{sat}} \sum_{k=1}^N A_k \langle \mathbf{n}_k, \mathbf{r}_s \rangle \left[(1 - \rho_s^k) \mathbf{r}_s + 2 \left(\rho_s^k \langle \mathbf{n}_k, \mathbf{r}_s \rangle + \frac{\rho_d^k}{3} \right) \mathbf{n}_k \right]. \quad (5)$$

Again, as P_{srp} depends on the inverse distance to the Sun we can also rewrite the SRP acceleration in terms of the Sun gravitational potential, having:

$$\mathbf{a}_{srp} = -q_{srp} \frac{Gm_{sun}}{r_{ps}^2} \sum_{k=1}^N A_k \langle \mathbf{n}_k, \mathbf{r}_s \rangle \left[(1 - \rho_s^k) \mathbf{r}_s + 2 \left(\rho_s^k \langle \mathbf{n}_k, \mathbf{r}_s \rangle + \frac{\rho_d^k}{3} \right) \mathbf{n}_k \right], \quad (6)$$

where now $q_{srp} = \left(\frac{1}{m_{sat}} \right) \cdot \left(\frac{P_0 R_0^2}{Gm_{sun}} \right) = \left(\frac{7.7065 \times 10^{-4}}{m_{sat}} \right)$.

The main drawback of this approximation is the fact that auto-occultation between the different plates are not taken into account, and therefore, at specific attitudes an over or under estimation of this effect may be occurring.

Finite Element. This is a high-fidelity approach, where auto-occultation and secondary hits from the Sun-light can be taken into account [5, 6]. Using ray-tracing techniques, it can be determined which parts of the satellite are illuminated and how the light bounces off the surface depending on the different materials and the attitude with respect to \mathbf{r}_s . Unfortunately, this method is very expensive in terms of computational time and it is not advisable to compute the SRP accelerations simultaneously during an orbit simulation. In order to improve its performance, one should know the attitude profile in advance and compute the SRP acceleration for each one of the profiles, or approximate its value from a set of intermediate attitudes [7].

WFIRST MISSION BASELINE DESIGN AND STATIONKEEPING

The baseline trajectory for WFIRST has been computed using the ATD module developed by Natasha Bosanac [1]. One of the advantages of this module is that it allows the user to find transfer trajectories from Low-Earth Orbits (LEOs) to Halo or Quasi-Halo orbits using a Dynamical System Theory (DST) approach. Having an agile tool which allows the user to analyze different options and launch opportunities, allows for Flight Dynamics Engineers to find feasible mission orbits quickly and easily.

The module starts with the Circular RTBP and allows the user to select a set of target LPOs, based on the mission requirements, from a catalogue of Libration Point orbits. In the case of WFIRST, there is an upper bound for the angle between the Earth-to-satellite and the Earth-to-L2 vectors. This angle must remain below 36° [1]. Then a grid search to find transfer trajectories from

LEO to the stable manifolds of the set of selected Halo orbits is performed. The insertion on the stable manifold of a Halo orbit ensure low-cost insertion maneuvers to the target Halo orbit. Once we find the desired transfer trajectory in the RTBP, this orbit is refined on a higher fidelity model. Finally, one can set the number of revolutions around the Halo orbit the mission requires, and refine this Halo orbit into a Quasi-Halo orbit in the full ephemeris system. In the case of WFIRST, the mission baseline has been generated up to 10 years. For further details on the module see Reference [1].

As we know, the L_2 environment is highly unstable, requiring routine stationkeeping maneuvers to remain in a bounded orbit. In the literature we can find different approaches to this problem. For WFIRST we propose to use a Dynamical System approach, introduced in References [1, 8]. Let us briefly describe the main aspects of this stationkeeping strategy. Using the ATD module we obtain a set of reference target points $\{\mathbf{p}_i\}$ on $Y=0$ plane. Each time a Δv maneuver is planned, we compute the STM of a reference orbit and find the stable (\mathbf{v}_s) and unstable (\mathbf{v}_u) eigenvectors. We then look for the Δv maneuver in the stable direction (\mathbf{v}_s) that minimizes the Δv required to reach one of the target points, \mathbf{p}_i , on the $Y=0$ plane crossing. This ensures us a low-cost maintenance for the stationkeeping.

Additionally, WFIRST will perform routine Momentum Unloads (MUs) to unload stored momentum in the reaction wheels. These MUs can be seen as systematic random perturbation in the velocity vector. Orbit determination errors can also be modeled as errors on the position and velocity each time a stationkeeping maneuver is performed. All these uncertainties will be included in our simulations.

SOLAR RADIATION PRESSURE ANALYSIS

In this section we provide a detailed analysis on the SRP acceleration and its effect on the stationkeeping of WFIRST. We must mention that we still do not have full information on the final structure of WFIRST and details on the materials that will be covering the satellite so we have made some assumptions. The purpose of the paper is to show the importance of SRP modeling, and we believe that the results presented here are interesting and relevant. In this section we will show how the different models determine the size and direction for the SRP acceleration. We will also compare how these different models affect the performance of the stationkeeping strategy.

Comparison between different SRP models for WFIRST

As mentioned in a previous section, the most common and simplified model for SRP is the Cannonball model, where the magnitude and direction of the SRP acceleration are fixed. We want to see how much the magnitude of the SRP acceleration varies when considering more realistic models. Given that WFIRST has a large solar panel, which will be facing the Sun during the mission in order to charge its battery, a simple improvement to the Cannonball is to consider a single plate the size of the solar panel. We also have considered a 14 plate approximation of WFIRST from a simple computer aided-design (CAD) model and a Finite Element model.

Cannonball vs 1-Plate model. Let us compare the total SRP acceleration between the Cannonball and 1-plate representing WFIRST's solar panel. The radiation pressure at the L_2 vicinity is $P_{srp} \approx 4.4799 \times 10^{-6}$ and the estimated area-to-mass ratio for WFIRST is $0.06 \text{ m}^2/\text{kg}$. Hence, from Eq. (3) $\mathbf{a}_{srp} = -C_r K_{sun} \mathbf{r}_s$, and Eq. (5) $\mathbf{a}_{srp} = -K_{sun} \langle \mathbf{n}, \mathbf{r}_s \rangle \left[(1 - \rho_s) \mathbf{r}_s + 2 \left(\rho_s \langle \mathbf{n}, \mathbf{r}_s \rangle + \frac{\rho_d}{3} \right) \mathbf{n} \right]$, where $K_{sun} \approx 2.6879 \times 10^{-7}$. In this second expression, $\langle \mathbf{n}, \mathbf{r}_s \rangle = \cos \alpha$, where α is the offset angle between the normal vector to the plate surface, \mathbf{n} , and the Sun-satellite direction, \mathbf{r}_s . In order to be able to charge the battery with the solar panels, the angle α should be kept between

$[-40^\circ, 40^\circ]$ during the mission. As mentioned before, the coefficient $C_r \in [1,2]$ is hard to determine and depends on the reflectivity properties of the satellite. Concerning the 1-plate model, we have assumed $\rho_d = 0$ (as this value is usually very small) and $\rho_s \neq 0$. Note that $\rho_s = 0$ means that all the solar photons are absorbed (this would be a perfect solar panel) and $\rho_s = 1$ means that all the solar photons are reflected (this would be a perfect solar sail). For the simulations on this paper we have considered that for WFIRST $\rho_s \approx 0.25$.

Figure 1 (left) shows the SRP acceleration variation for different C_r and ρ_s values as a function of the offset angle α . Figure 1 (right) shows the angle difference between the SRP acceleration using the cannonball model and the 1-plate model as a function of the offset angle α . As we can see, if we consider $\rho_s \approx 0.25$ for the 1-plate model then a cannonball approximation with $C_r = 1.25$ seems appropriate.

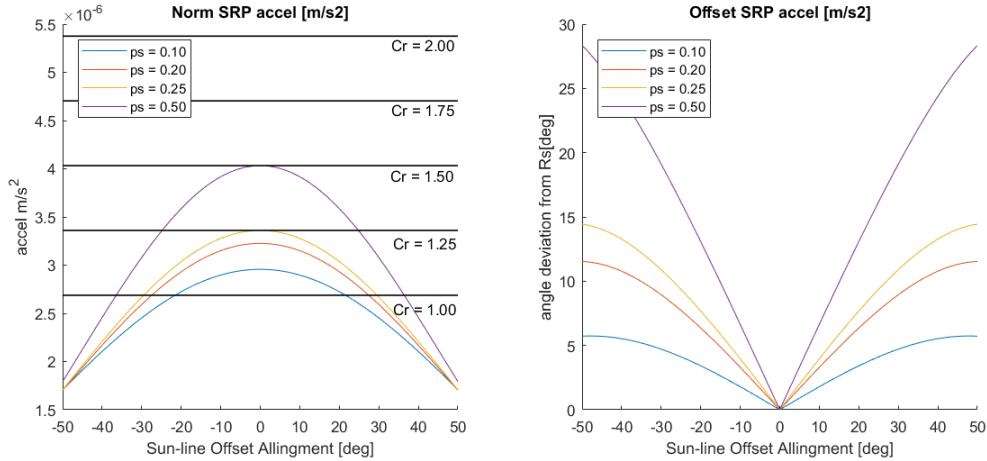

Figure 1: Variation of the SRP acceleration depending on the offset angle (left). Variation in angle between the Cannonball and 1-plate accelerations as a function of the offset angle (right)

N-Plate model vs Finite Element. As we know the shape for WFIRST is more complex than a simple flat plate. Figure 2 shows a simple CAD model representation of WFIRST's approximated shape. For simplicity we have considered a satellite with two different materials, silver foil (representing MLI blanketing material typically used on spacecraft) covering the full telescope (with an assumed $\rho_s = 0.55$ and $\rho_d = 0.0$) and a solar panel where $\rho_s = 0.25$ and $\rho_d = 0.0$.

Using ray-tracing techniques [6, 7] we have computed the total SRP for a set of different attitudes. For comparison, we have also computed the SRP acceleration of a 1-plate model where the plate has the same reflectivity properties as the solar panel ($\rho_s = 0.25$ and $\rho_d = 0.0$), and a 14-plate approximation (see Table 1) with the same reflectivity properties as the CAD model shown in Figure 2. Figure 3 shows the total acceleration for these three models for different attitudes, where $az \in [-180^\circ, 180^\circ]$ and $el \in [-90^\circ, 90^\circ]$ are the satellites azimuth and elevation with respect to the Sun-satellite direction \mathbf{r}_s . As we can see, the maximum and minimum values for the SRP acceleration for all three models are very similar. WFIRST's attitude will change throughout its mission orbit as it is observing different regions of the sky. We need to understand how the variations in the SRP acceleration affect the stationkeeping around WFIRST's mission orbit.

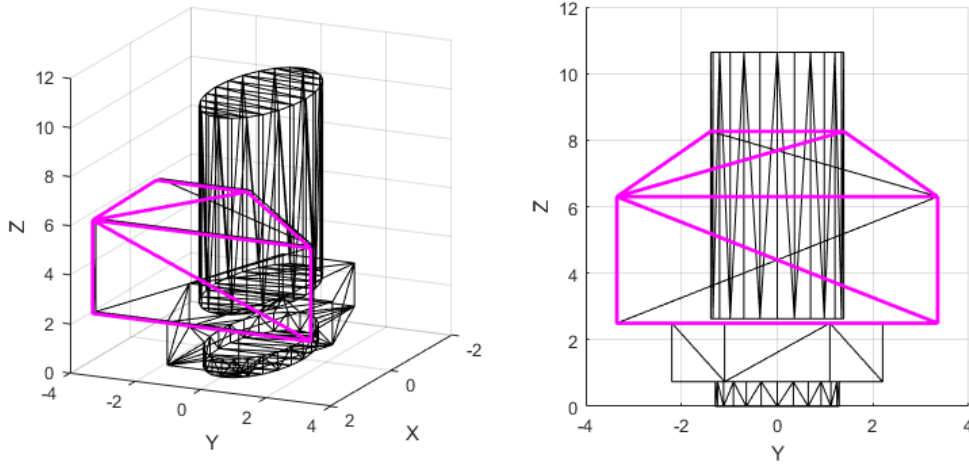

Figure 2 CAD model representation of WFIRST structure from two different viewpoints, each color represents different materials. Magenta for the solar panel and black for the silver foil.

Table 1. Elements of the 14-plate Approximation for WFIRST.

Plate ID	Area (m ²)	ρ_s	ρ_d	\mathbf{n}
1	34.7505	0.25	0.0	(1.000, 0.000, 0.000)
2	8.4421	0.55	0.0	(1.000, 0.000, 0.000)
3	23.3292	0.55	0.0	(-1.000, 0.000, 0.000)
4	18.7376	0.55	0.0	(-1.000, 0.000, 0.000)
5	23.3281	0.55	0.0	(0.000, 1.000, 0.000)
6	23.3281	0.55	0.0	(0.000, -1.000, 0.000)
7	12.5730	0.55	0.0	(0.000, 0.000, 1.000)
8	12.5730	0.55	0.0	(0.000, 0.000, -1.000)
9	3.8720	0.55	0.0	(1.000, 0.000, 0.000)
10	3.8720	0.55	0.0	(-1.000, 0.000, 0.000)
11	3.8720	0.55	0.0	(0.000, 0.866, 0.500)
12	3.8720	0.55	0.0	(0.000, -0.866, 0.500)
13	3.8720	0.55	0.0	(0.000, -0.866, -0.500)
14	3.8720	0.55	0.0	(0.000, 0.866, -0.500)

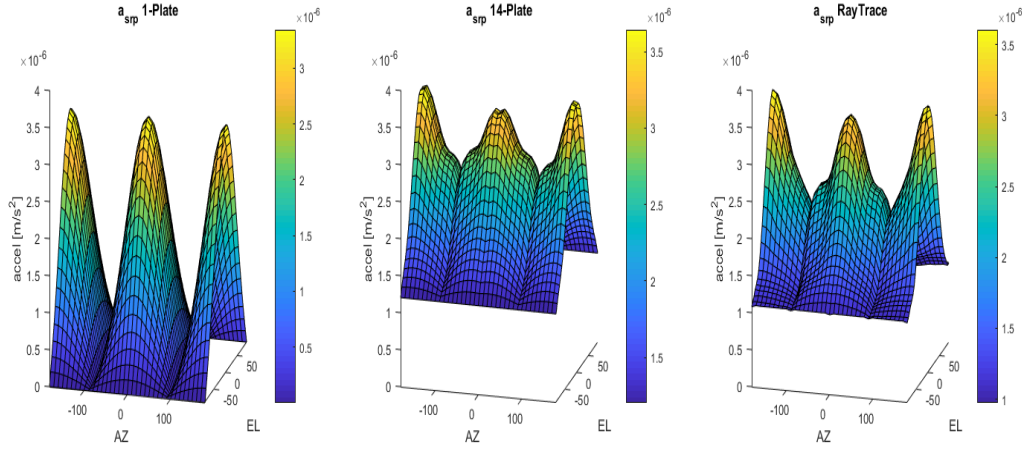

Figure 3: Variation of the solar sail acceleration as a function of the Sun-line direction

Impact of Solar Radiation Pressure on the Dynamics at LPO

Let us now focus on the direct impact that SRP has on the natural dynamics of WFIRST. A good initial reference model is the RTBP, which is used in the ATD module [1] in order to design a reference baseline for WFIRST. It is already known, that when we include SRP in the RTBP, all of the equilibrium points are displaced towards the Sun and so are the periodic and quasi-periodic orbits around L_2 [2, 9]. The rate of displacement will depend on the size of the perturbation (q_{srp}).

Notice that if we include Eq. (4) into the RTBP expression in Eq. (1) the equations of motion can be rewritten as:

$$\begin{aligned}
 \ddot{X} - 2\dot{Y} &= 2X - (1 - q_{srp}) \frac{1-\mu}{r_{ps}} (X + \mu) - \frac{\mu}{r_{pe}} (X + 1 - \mu) + a_x, \\
 \ddot{Y} + 2\dot{X} &= 2Y - \left((1 - q_{srp}) \frac{1-\mu}{r_{ps}} + \frac{\mu}{r_{pe}} \right) Y + a_y, \\
 \ddot{Z} &= - \left((1 - q_{srp}) \frac{1-\mu}{r_{ps}} + \frac{\mu}{r_{pe}} \right) Z + a_z.
 \end{aligned} \tag{6}$$

If we consider that the area-to-mass ratio for WFIRST is $0.06 \text{ m}^2/\text{kg}$, the $q_{srp} = C_r \cdot 4.6239 \times 10^{-5}$. The equations of motion can be seen as a modified RTBP where we have slightly changed the gravitational attraction from the Sun.

Table 2 shows the displaced location of L_2 for $C_r = 0.0$ (no SRP), $C_r = 1.25$ and $C_r = 2.0$, with its corresponding q_{srp} value. One can see that L_2 is displaced about 950 km for $C_r = 1.25$ and about 1,500 km for $C_r = 2.0$.

Table 2. Relationship between the location of L_2 and different C_r values for WFIRST.

C_r	q_{srp}	L_2 location (km)	L_2 location (AU)
0.00	0.0	151,105,099.17	1.0100752000206037
1.25	5.7799×10^{-5}	151,104,145.49	1.0100688251150842
2.00	9.2472×10^{-5}	151,103,573.97	1.0100650046967869

Figure 4 shows the displaced Halo orbit family for different C_r values. On the left, we have the family of Halo orbits for $C_r = 0$ (blue) and $C_r = 2.0$ (magenta). On the right, we have the projection of the Halo orbits on the $Y = 0$ plane, where we can better visualize the displacement between the orbits for different C_r values. One can see that the Halo orbits for $C_r = 1.25$ are displaced approximately 1,300 km from the no SRP Halo, while the Halo orbits for $C_r = 2.0$ are displaced more than 2,000 km from the no SRP Halo orbits. Although this displacement might seem small, if we compare them with the Earth - L2 distance (151,105,099 km), as we will see in the next section, it does have a big impact on the stationkeeping.

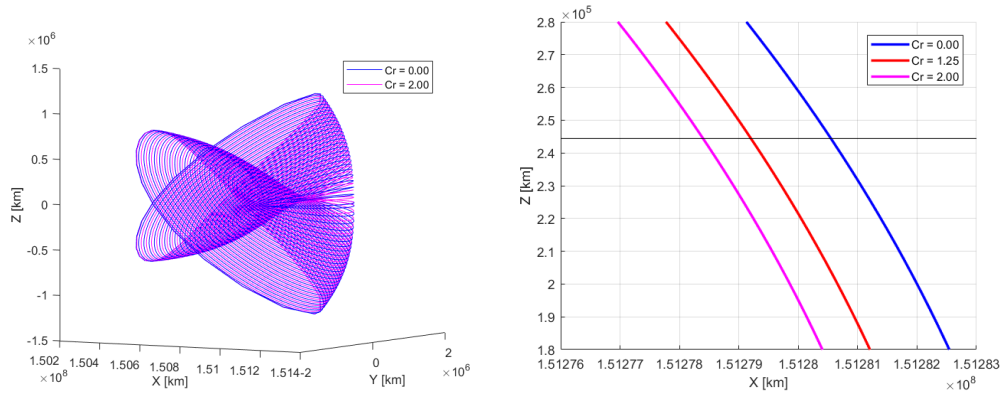

Figure 4 Family of Halo orbits for $C_r = 0$ and $C_r = 2$ (left). Projection of the Family of Halo orbits on the section $Y=0$ for $C_r = 0$, $C_r = 1.25$ and $C_r = 2$ (right)

When we consider the ephemeris model described in the Force Models section, we can find natural trajectories in this higher fidelity model that are close to a Halo orbit in the RTBP, which we will use as reference trajectories for WFIRST. Figure 5 shows the refinement of three different Halo orbits with a Z amplitude of about 245000 km in the higher fidelity model. Notice that the displacement between Halo orbits observed in the RTBP still holds in the ephemeris model. One can check that the distance between the $C_r = 1.25$ refined Halo orbit and the no SRP Halo orbit is around 1,430 km on the $Y=0$ section. However, the distance between the $C_r = 2.0$ refined Halo orbit and the no SRP Halo orbit on the $Y=0$ section is close to 2,400 km. Notice that these numbers are consistent with the displacement observed in the RTBP (Figure 4).

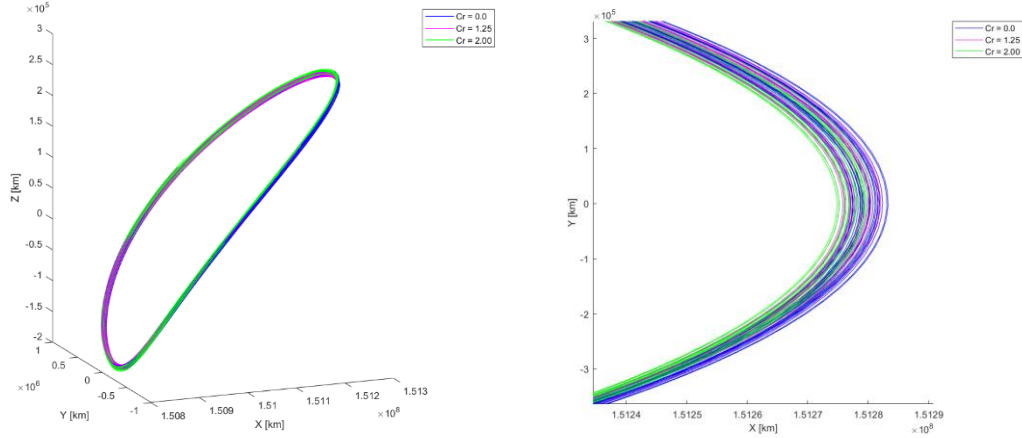

Figure 5 Displaced Halo orbits in the ephemerides model (left). Zoomed in image of Displaced Halo orbits in the XY plane (right).

When considering the N-plate model (with a single or several plates) the implications of SRP on the natural dynamics are similar to the solar sail problem for a low-reflecting solar. In this case, for a fixed attitude throughout the whole mission, the location of the equilibrium points and the Libration point orbits are also be displaced [2, 9]. It is true that during the science mission WFIRST will vary its attitude when observing different regions of the sky. However, if we know the reference attitude in advance, or an average of the attitude with respect to the Sun-line, we could have an idea of how displaced the reference or natural trajectory for WFIRST would be.

Impact of Solar Radiation Pressure on the Stationkeeping

Let us now discuss the impact of SRP on the stationkeeping. Let us recall the main aspects of the stationkeeping strategy. From the ATD module we have a set of reference target points $\{p_i\}$ on $Y=0$ plane, each target point related to an epoch or orbit revolution. Each time a Δv maneuver is planned, we compute the STM of a reference orbit and find the stable (v_s) and unstable (v_u) eigenvalues. We then find the Δv maneuver in the stable direction (v_s) that minimizes the Δv required in order to reach the target points p_i related to the next $Y=0$ orbit crossing.

As we see, this strategy relies on the location of the target points p_i of a given reference trajectory, which have been precomputed with the ATD module. In the previous section we showed how changing the reflectivity properties (i.e. the C_r value) of the satellite will make the reference trajectory displace more than 1000 km. Hence, the tolerance for achieving the p_i target points will have a strong impact on the cost of the Δv maneuvers. To illustrate this, we have performed a simple test. We have precomputed two reference trajectories for WFIRST, one without SRP in the ephemeris model (called **REFCr0**), and another one including SRP with $C_r = 2.0$ (called **REFCr2**). We have used these two different reference trajectories and performed a stationkeeping campaign for 5 years around each reference orbit.

For each of the reference trajectories (**REFCr0** and **REFCr2**) we have performed simulations with different SRP approximations, using the Cannonball model with $C_r = 0.0, 1.25$ and 2.0 . Moreover, we have included random MUs every week. For our simulations, we have considered MUs of different sizes: 1.3mm/s and 13.3mm/s (an optimistic and a pessimistic value for its magnitude). With this we want to see the tradeoff between how the SRP effect and the size of the MUs impact the total Δv cost.

Figure 6 summarizes the results for 5 different simulations for each C_r value using **REFCr0** as reference target points. Notice that for MUs of 1.33mm/s the simulations with $C_r = 0.0$ have a smaller total cost than the $C_r = 2.0$ simulations, and $C_r = 1.25$ is in the middle. This is expected given that the reference trajectory has been obtained from a simulation with no SRP. On the other hand, if we look at the simulation with larger MUs, the average cost of the different simulations seems to be close for each of the C_r values.

Figure 7 summarizes the results for 5 different simulations for each C_r value using **REFCr2** as reference target points. Notice that now, for MUs of 1.3mm/s, the simulations with $C_r = 2.0$ are the ones with a minimum cost and $C_r = 0.0$ the largest. This is completely opposite of the previous case. These results might surprise the reader, given that one might think that including SRP will have a destabilizing effect on the station keeping strategy. But the truth is that, SRP essentially displaces the location of the reference Halo orbit, and if we are able to find the “natural” displaced Halo orbit, we can considerably reduce the total cost. This is the case here where we are using **REFCr2** which includes SRP, with $C_r = 2.0$, as a reference orbit. If we focus on the results for larger MUs, on the right of Figure 7, we see that again the average cost for the simulations with different C_r values is the same.

We can think of the MUs as random displacements of WFIRST along its trajectory. The larger the size of the MUs, the more we are displaced from a reference trajectory, and the more expensive the Δv required to return to this reference trajectory will be. In this case, having a good reference trajectory is not as important as for small MUs where the required Δv where small.

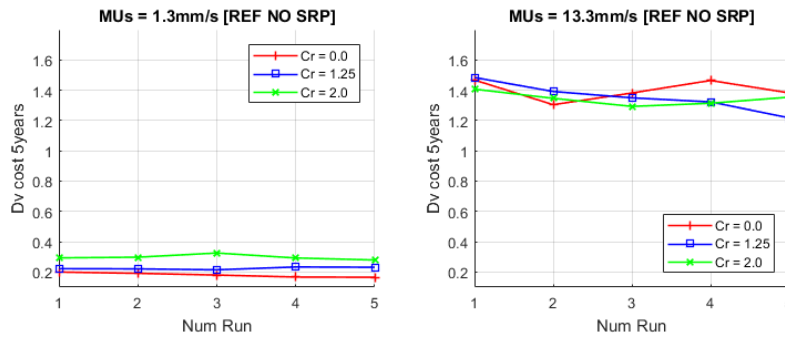

Figure 6 Δv cost for 5 year simulations using a No SRP reference trajectory for different C_r values. Results with MUs of 1.0mm/s (left) and MUs of 10mm/s (right).

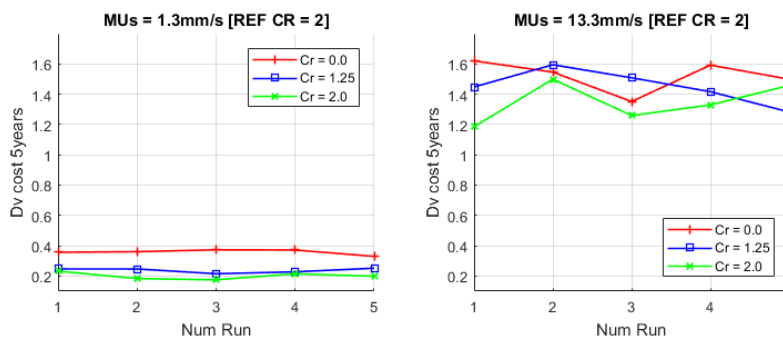

Figure 7 Δv cost for 5 year simulations using a $C_r = 2$ reference trajectory for different C_r values.

Let us now see how relevant the SRP effect is when we consider the N-plate model instead of the Cannonball model described above. Now we have the attitude offset with respect to the Sun line direction that will play an important role. For these simulations we have considered *REFCr2* as a reference trajectory (given that we have no reference trajectory for an N-plate model) and a single plate with $\rho_s = 0.25$, $\rho_d = 0.0$ for the SRP model, with the same area-to-mass ratio as the cannonball model ($0.06 \text{ m}^2/\text{km}$). As in the previous section, we have performed 5 year simulations with random MUs of 1.3mm/s, 6.6mm/s and 13.3mm/s and different offset angles. We note that the offset angle is kept fixed throughout the full simulation. With these assumptions, if the plate is perpendicular to the Sun line (offset angle $\alpha = 0^\circ$) the results should be the similar as for the cannonball model with $C_r = 1.25$.

Table 3: Total Δv cost for 5 years stationkeeping with no MUs for a fixed offset angle.

Offset Angle	$\alpha = 0^\circ$	$\alpha = 10^\circ$	$\alpha = 20^\circ$	$\alpha = 40^\circ$
Total Δv	0.1287 m/s	0.1355 m/s	0.1848 m/s	0.2754 m/s

Table 3 shows the total Δv cost of a 5 years stationkeeping simulation with no MUs. For different offset angles, we see the total cost increases as the offset increases. Figure 8 summarizes the results for different offset angles ($\alpha = 0^\circ, 10^\circ, 20^\circ$ and 40°) and MUs = 1.3 mm/s (left), MUs = 6.6 mm/s (middle), and MUs = 13.3 mm/s (right). As in the previous cases, when the MUs are large it is hard to see the effect of the plates orientation with respect to the Sun line. On the other hand, for MUs = 1.3 mm/s and 6.6 mm/s we can see that the larger the offset angle, the larger the required Δv cost is. As mentioned in the previous section, a constant attitude also displaces the reference trajectory and this explains the results observed here.

During WFIRST's observation campaign, its attitude will change in order to observe the differ-

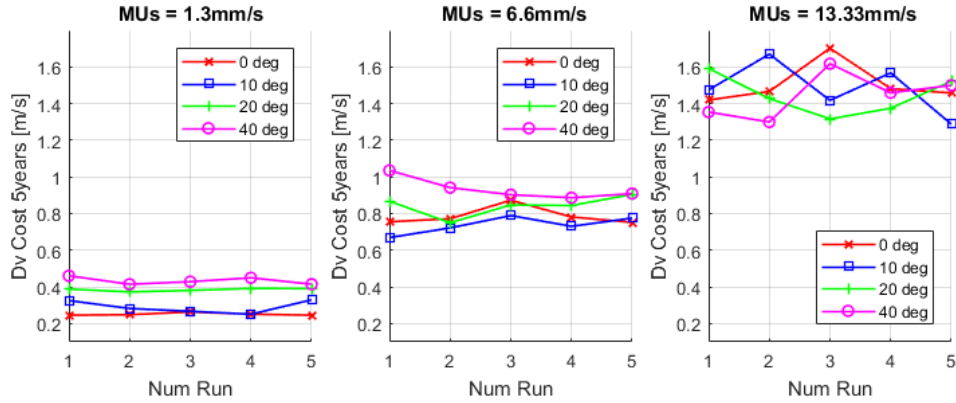

Figure 8 Δv cost for 5 year simulations using a $C_r = 2$ reference trajectory for different offset angles and MUs.

ent regions in space and to perform MUs and stationkeeping maneuvers. We still need to study in more detail what is the effect of a changing attitude profile on the stationkeeping cost. Looking at the results above, we can see the importance of knowing the planned attitude for observations prior to planning stationkeeping maneuvers. Knowing the planned attitude, we can help minimize the total stationkeeping costs by directing WFIRST to a reference trajectory it would follow in its natural motion, rather than by forcing it to a reference trajectory for which it is too far displaced.

ORBITAL NAVIGATION ANALYSIS

Another error source that needs to be taken into consideration for stationkeeping planning is the Orbit Determination (OD) or Navigation error. In order to plan stationkeeping maneuvers, Flight Dynamics Engineers need to have knowledge of WFIRST's velocity within 5% of the planned maneuver. WFIRST is currently baselining the use of NEN and DSN ground stations for their OD processes. While most of these ground stations produce accurate Range and Doppler measurements, there are still noise and biases in their signals that cause error in the WFIRST position and velocity knowledge. These noise and biases tend to produce steady-state position errors under 5 km and velocity errors under 5 cm/s. Using daily Range and Doppler passes from these ground stations, WFIRST will have a definitive knowledge error in the single digit km for position and single digit cm/s for velocity on average.

In a previous OD error analysis performed by the Flight Dynamics team, covariance matrices prior to each stationkeeping maneuver were generated for a year in WFIRST's orbit. Taking the eigenvalues of each matrix and applying a standard deviation and random error in MATLAB, we are able to develop random position and velocity errors to apply to our satellite state prior to each stationkeeping maneuver. This allows us to essentially model an OD error prior to each stationkeeping maneuver. Using these OD errors in combination with the different SRP models, one can see the effects on the overall stationkeeping Δv . A sample of the position and velocity components of 10 cases of random errors for one stationkeeping maneuver are shown in Figure 9.

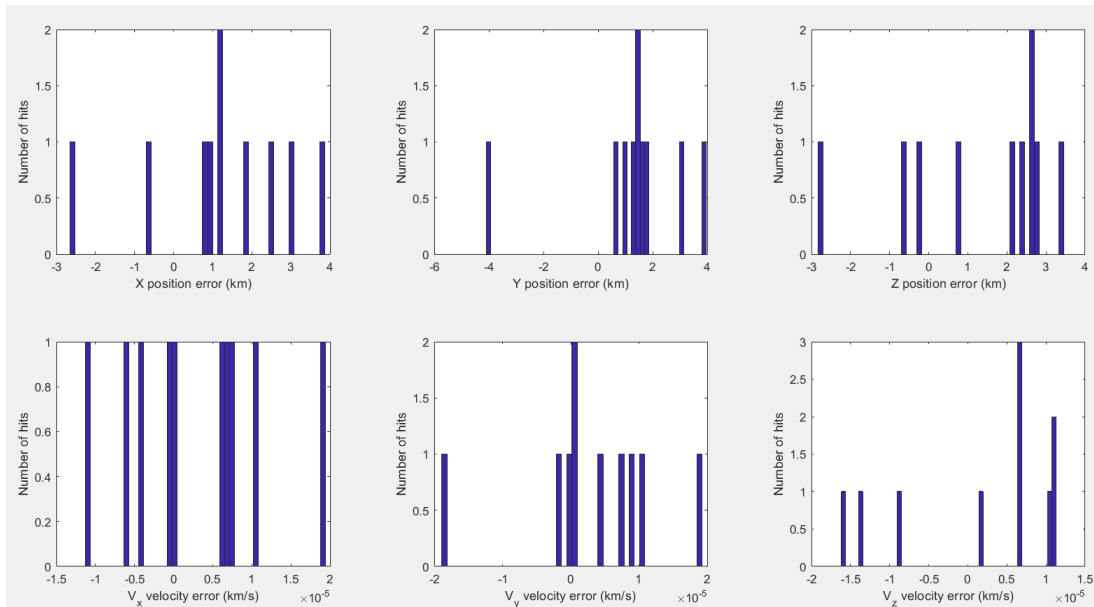

Figure 9 Sample of 10 Position and Velocity OD Error Components for a Stationkeeping Maneuver

Using these OD component errors, we are able to run a number of cases (for this analysis we have done 10) to see how stationkeeping Δv is affected by the Momentum Unload residual Δv and the SRP model. Assuming the stationkeeping is done at a 21-day cadence, there are 17 stationkeeping maneuvers that will be planned for 1-year in orbit. So, for each analysis case, running 10 random OD errors on each stationkeeping maneuver for one year in orbit, 170 maneuvers are generated. A 5% maneuver execution error was also applied to each stationkeeping maneuver to represent the misalignment of the thrusters onboard WFIRST. This provides us a decent sample size to

evaluate how much Δv is required for stationkeeping on WFIRST each year. An illustration of the stationkeeping process with OD and maneuver execution errors is shown in Figure 10.

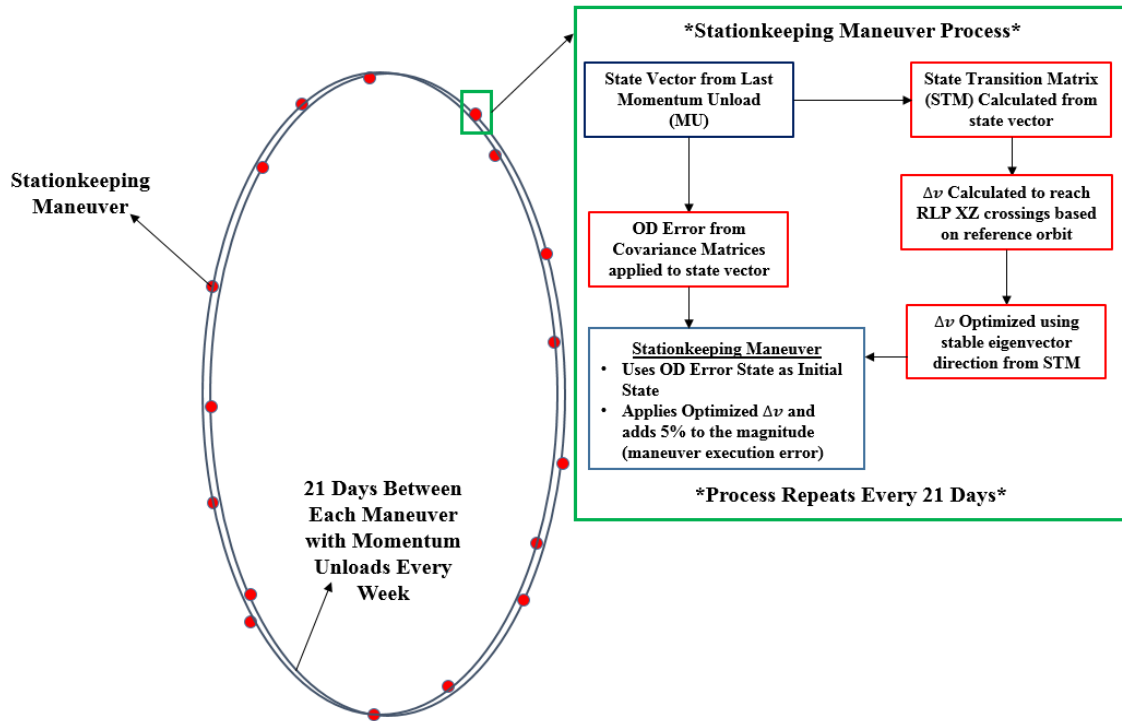

Figure 10 Illustration of Stationkeeping Process (explained in green box) for one year orbit (blue lines) with stationkeeping maneuvers (red dots). Stationkeeping maneuvers are planned every 21 days with Momentum Unloads every week.

To understand how the stationkeeping Δv is affected by SRP, we first begin with the cannonball model. For this model, we have run four different analysis cases:

- Case 1: Cannonball using $C_r = 0$ with 1.33 mm/sec residual Δv Momentum Unloads
- Case 2: Cannonball using $C_r = 0$ with 13.33 mm/sec residual Δv Momentum Unloads
- Case 3: Cannonball using $C_r = 2$ with 1.33 mm/sec residual Δv Momentum Unloads
- Case 4: Cannonball using $C_r = 2$ with 1.33 mm/sec residual Δv Momentum Unloads

For each case, we ran a year's worth of stationkeeping maneuvers with 10 different OD errors (so 170 maneuvers were calculated for each case). For each case the total stationkeeping Δv was calculated. The results along with the maximum OD position and velocity errors are shown below in Table 4.

Table 4. Stationkeeping Δv with Orbit Determination Errors and Cannonball SRP Model.

Analysis Case	C_r Value Used in Analysis and Reference Orbit	Momentum Unload Residual Δv (mm/s)	Maximum Position OD Error (km)	Maximum Velocity OD Error (cm/s)	Average Total Stationkeeping Δv for 1 Year (m/s)
1	0	1.33	9.57	3.22	1.12
2	0	13.33	12.81	3.83	1.20
3	2	1.33	13.72	4.04	1.06
4	2	13.33	10.75	4.53	1.16

Looking at the results in Table 2, we can see that using the Cannonball SRP model with a C_r of 0 results in larger total stationkeeping Δv than using the Cannonball SRP model with a C_r of 2. In general, it appears that the residual Δv of the Momentum Unloads does not have a drastic effect on the total yearly stationkeeping Δv . While the Cannonball SRP model is not the most accurate one to use for WFIRST, this provides us with a good baseline for our 1-plate SRP model to compare results with.

We now will repeat the same analysis as before, but with the 1-plate SRP model. We ran the analysis with the same offset angles as before for comparison purposes. For the 1-plate model, we have run eight different analysis cases:

- Case 1: 1-plate Model with 0° offset and 1.33 mm/sec residual Δv Momentum Unloads
- Case 2: 1-plate Model with 0° offset and 13.33 mm/sec residual Δv Momentum Unloads
- Case 3: 1-plate Model with 10° offset and 1.33 mm/sec residual Δv Momentum Unloads
- Case 4: 1-plate Model with 10° offset and 13.33 mm/sec residual Δv Momentum Unloads
- Case 5: 1-plate Model with 20° offset and 1.33 mm/sec residual Δv Momentum Unloads
- Case 6: 1-plate Model with 20° offset and 13.33 mm/sec residual Δv Momentum Unloads
- Case 7: 1-plate Model with 40° offset and 1.33 mm/sec residual Δv Momentum Unloads
- Case 8: 1-plate Model with 40° offset and 13.33 mm/sec residual Δv Momentum Unloads

For each case, we ran a year's worth of stationkeeping maneuvers with 10 different OD errors (so 170 maneuvers were calculated for each case). For each case the total stationkeeping Δv was calculated. The results along with the maximum OD position and velocity errors are shown below in Table 5.

Table 5. Stationkeeping Δv with Orbit Determination Errors and N-Plate Model.

Analysis Case	1-Plate Offset Angle ($^{\circ}$)	Momentum Unload Residual Δv (mm/s)	Maximum Position OD Error (km)	Maximum Velocity OD Error (cm/s)	Average Total Stationkeeping Δv for 1 Year (m/s)
1	0	1.33	8.43	3.14	0.92
2	0	13.33	10.62	4.09	0.99
3	10	1.33	11.31	4.62	0.91
4	10	13.33	9.82	3.87	0.97
5	20	1.33	7.64	4.17	0.89
6	20	13.33	16.27	4.54	1.02
7	40	1.33	10.94	3.75	0.88
8	40	13.33	12.03	4.03	0.95

Looking at the results in Table 5, we can see that overall, using the 1-plate model resulted in smaller total stationkeeping Δv 's than any of the Cannonball SRP models. We also can see that the 1-plate model with 0° compares very well with our Cannonball model using a C_r of 2. This gives us confidence in how our 1-plate model is designed. Once again, it appears that the residual Δv of the Momentum Unloads does not have a drastic effect on the total yearly stationkeeping Δv . With these results, and confidence in our 1-plate model, we can see that having an accurate N-plate model can help WFIRST save stationkeeping Δv . The stationkeeping Δv could be smaller than the Cannonball model because the SRP is helping balance WFIRST in its orbit, driving the maneuver magnitude down. In some places in the orbit, and with the 1-plate orientation at that time, the SRP effect may be pushing/pulling WFIRST naturally onto its targeted reference orbit. This needs to be studied further with realistic attitude profiles for WFIRST at the time of the stationkeeping maneuvers to see if using the SRP and orientation can help keep the maneuver magnitudes down.

Overall, the results from combining the different SRP models and OD errors have shown us that the N-plate model will be the more accurate, and cost efficient in terms of Δv , as we move forward in our mission design and maneuver planning.

CONCLUSION

In this paper we have analyzed how the SRP acceleration uncertainties, the size of the MUs and orbital determination errors affect the total cost of stationkeeping of WFIRST's mission orbit.

We have seen that, when the MUs and the orbital determination errors are small, it is important to have a good reference orbit that takes into account the different forces affecting the motion of

the satellite. In this case a good approximation of the SRP acceleration on knowledge of the satellite's attitude with respect to the Sun-satellite line are required in order to minimize the total Δv . If the size of the MUs and the orbital determination errors are large, despite having a good reference trajectory, the required Δv to remain close to the nominal orbits drastically increases. For this reason, it is important to improve the precision on the orbital determination. While WFIRST is currently baselining the use of ground stations for Range and Doppler, we will continue further investigation into the possibility of doing celestial based navigation on WFIRST. Using this technique, the OD accuracy that can be achieved on WFIRST will only further improve and will help decrease the OD errors we have seen in this analysis so far.

As we move forward in our design phase on WFIRST, we plan to further calibrate our N-plate models to accurately represent the WFIRST spacecraft model and solar array panels. We will also add notional attitude profiles for the observatory as it moves through its mission orbit, and determine what the attitude will be prior to each stationkeeping maneuver. Knowing the attitude orientation prior the maneuver will only further help to minimize the Δv . We will run Monte Carlo analyses with our SRP errors, maneuver execution errors, and OD errors to have a complete understanding of what the average stationkeeping Δv will be each year for WFIRST.

ACKNOWLEDGMENTS

This work has been funded by the WFIRST project under the Goddard Planetary Heliophysics Institute Task 595.001 in collaboration with the University of Maryland Baltimore County (UMBC) under NNG11PL02A.

REFERENCES

- [1] N. Bosanac, C. M. Webster, K. Howell and D. C. Folta, "Trajectory Design and Station-Keeping Analysis for the Wide Field Infrared Survey Telescope Mission," in *AAS/AIAA Astrodynamics Specialist Conference*, 2017.
- [2] A. Farres and A. Jorba, "Periodic and Quasi-Periodic Motion of a Solar Sail close to SL1 in the Earth-Sun System," *Celestial Mechanics and Dynamical Astronomy*, vol. 107, no. 1-2, pp. 233-253, June 2010.
- [3] A. Milani, A. Nobili and P. Farinella, *Non-gravitational perturbations and satellite geodesy*, 1987.
- [4] D. A. Vallado, *Fundamentals of Astrodynamics and Applications*, 2001.
- [5] M. Ziebart and P. Dale, "Analytical Solar Radiation Pressure Modeling for GLONASS using a pixel array," *Journal of Geodesy*, vol. 75, pp. 587-599, 2001.
- [6] M. Ziebart, "Generalized Analytical Solar Radiation Pressure Modeling Algorithm for Spacecraft of Complex Shape," *Journal of Spacecraft and Rockets*, vol. 41, 2004.
- [7] A. Farres, D. C. Folta and C. Webster, "Using Spherical Harmonics to Model Solar Radiation Pressure Accelerations," in *AAS/AIAA Astrodynamics Specialist Conference*, 2017.
- [8] T. A. Pavlack and K. Howell, "Strategy for long-term libration point orbit stationkeeping in the Earth-Moon system," *Advances in the Astronautical Sciences*, vol. 142, 2012.

- [9] A. Farres, C. Webster and D. C. Folta, "High fidelity modeling of SRP and its effect on the relative motion of Starshade and WFIRST," in *AIAA SciTech Forum, 2018 Space Flight Mechanics Meeting*, 2018.